

SPECIFICATION SHEET

SC-DH-XX Round, 2 Position, 2-wire, Motorized Control Dampers

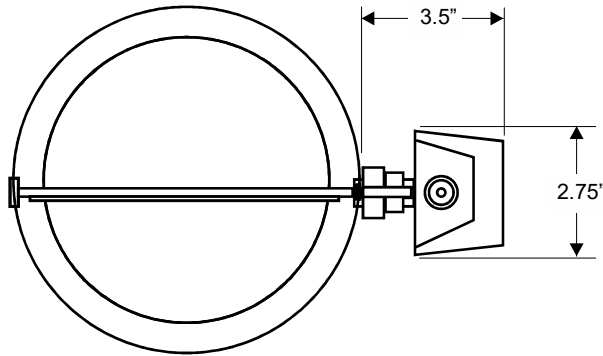

DAMPER SIZE	"A" DIMENSION
6"	10"
8"	10"
10"	10"
12"	10"
14"	10"
16"	10"
18"	10"
20"	10"

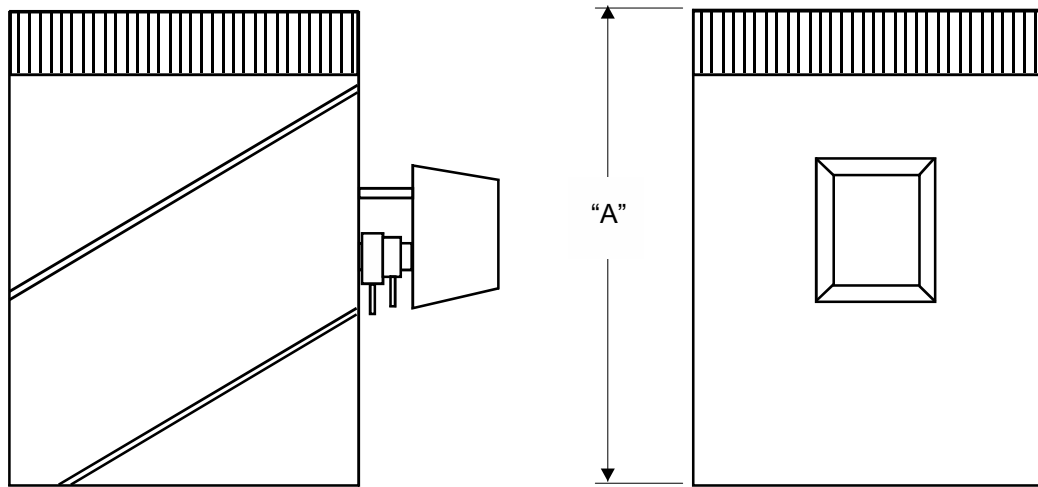

SPECIFICATIONS

DIMENSIONS:

Damper models SC-DH-XX are available in standard sizes from 6" to 20"

APPLICATION:

Compatible for zone control, fresh air and other HVAC applications with static pressures less than 1.0" w.c.

CONSTRUCTION:

- 18 gauge spiral steel shell
- 18 gauge steel blade
- 1/2" aluminum shaft
- Nylon bushings
- Air tight blade seals
- Minimum position adjustment

ELECTRICAL:

- 24 Volt, 10 VA, 0.43 Amp powered closed, spring return open actuator
- Can be supplied with optional 120 Volt actuator
- Also available in powered open, spring return closed
- Motor is impedance protected with no end switches



5351 E. Thompson Road Box 128
Indianapolis, IN 46237
www.specifiedcontrols.com
Phone: 888.359.0365